

THE BLIND BOYS OF ALABAMA

STAGE PLOT

as of June 17, 2010

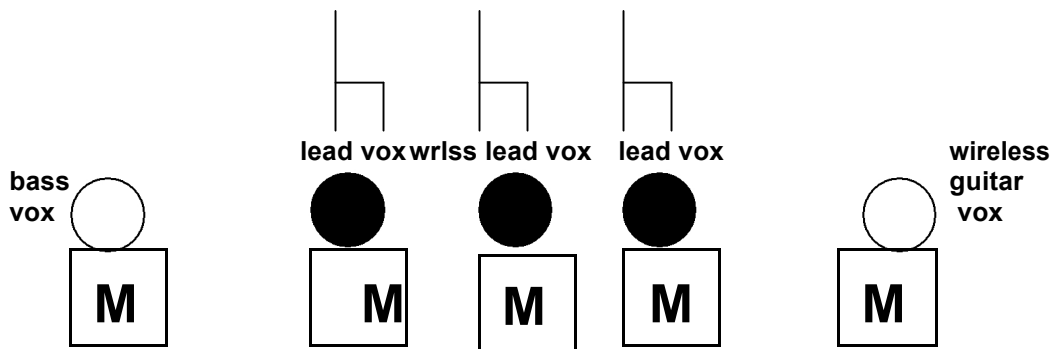
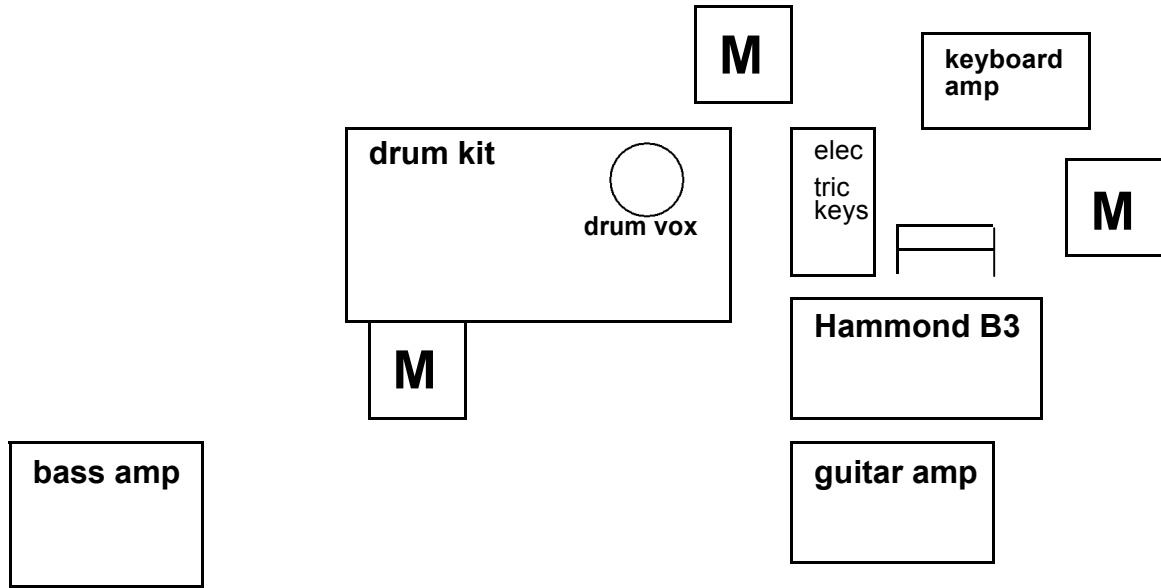

M = monitor

 = chair with no arms

 = straight stand microphone

 = boom stand microphone

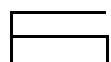
 = Hammond bench

BLIND BOYS OF ALABAMA - GEAR

EQUIPMENT NEEDED AT VENUE:

1. Thirty-two (32) Channel mixing board
2. One (1) HIGH quality reverb and one (1) unit delay
3. Two (2) effect sends
4. Seventeen (17) mics, stands (incl. 4 boom mic stands and 3 straight mic stands for vocals) and appropriate mic chords/cables
5. Two (2) radio mics (wireless) - **IMPORTANT**
6. Seven (7) monitors
7. Seven (7) monitor mixes preferred, Six (6) monitor mixes required
8. One (1) Direct input box
9. One (1) drum riser (8 ft x 8 ft x 8-16 inches high)
10. One (1) follow spotlight - **IMPORTANT**
11. 2-pack of AA batteries and 2-pack of 9-volt batteries
12. Three (3) chairs with backs but no arms for three lead vocalists

BACKLINE GEAR NEEDED:

1. One (1) guitar amp (Roland JC-120), two (2) guitar stands
2. One (1) Hartke XL bass amp with one 4 x 10" cabinet (with tweeter!) with 5500 head. If Hartke not available: please use Eden or Galien Kruger only.
For larger outdoor venues, two cabinets are required.
3. One (1) five-piece Taye drum kit. Drum kit needs: kick, 14" snare, 10" tom, 12" tom, 16" floor tom, 20" or 22" bass drum w/ kick drum pedal. In USA, call rep West Wheeler at 909-628-9589 or <wwheeler@tayedrums.com> to help locate local kit.
If Taye kit not available, please use Pearl or DW kit only.
Drum heads to have Coated Emperors for the toms, and a 14" CS Coated Controlled Black Dot for the snare with stand. Include two (2) pairs of Vic Firth 5A wood tip drumsticks, and two drum keys, please. Also include the following Sabian cymbals with stands: 1- 16" AAX thin crash, 1- 18" Studio Crash, 1- 20" Raw Ride or AAX Studio Ride, 1- 14" AAX or AA Medium Hi-Hat
4. One (1) Hammond B3 organ and Leslie speaker cabinet, with Hammond bench seat. If no Hammond B3 available, please use in order of preference: Nord C3 Combo Organ, Korg CX3 Combo Organ or Nord Electro 2 (76-key version only) plus Leslie speaker & Trek 2 pre-amp pedal. If no Leslie speaker available, alternate keys go through house.
5. One (1) Yamaha Motif 8 electric keyboard (Yamaha P250 is 2nd choice).
If Motif 8 not available, please use any weighted 88-key keyboard that plays as a piano.
6. One (1) Roland KC500 keyboard amp (if amp unavailable, must have 2nd keys monitor).

STAGE REQUIREMENTS:

A 24-feet-wide by 28-feet-deep and 16-inches-high stage. A staircase leading into the crowd from the stage is required for Jimmy to do his closing number. - **IMPORTANT**

IMPORTANT NOTE: We need both a Monitor Engineer and a FOH Engineer for the performance.

BLIND BOYS OF ALABAMA

INPUT LIST

(as of June 15, 2010)

<u>STAND</u>	<u>ITEM TO BE INPUT</u>
B1.	Kick
B2.	Snare
B3.	Hat
B4.	Tom
B5.	Tom
B6.	Tom
B7.	Over Condenser
B8.	Over Condenser
9.	Bass Amp Mic USR
10.	Electric Keyboard (stereo right and left direct)
11.	Keyboard Amp Mic
SB12.	Guitar Amp Mic SL
TB13.	Vocal Wireless SR
TB14.	Vocal Bass USR
S15.	Vocal CSL
S16.	Vocal Wireless CS
S17.	Vocal CSR
TB18.	Vocal Guitar SL
TB19.	Vocal Drums
20-21	FX
22-23	FX
24-25	FX

**For production questions and to advise of any substitutions
please contact Blind Ambition Management:
Tony Knuppel – 404-371-8252**